

Sky Saver

Prof. M. P. Sathe¹, Sandip D Parate¹, Ranjit V Gadpayle², B Hemaprabhu³,
Swapnil Jambhulkar⁴, Mohammad Shoeb⁵

¹ Associate Professor, Department of Mechanical Engineering, SRPCE, Nagpur

^{2,3,4,5} Students, Department of Mechanical Engineering, SRPCE, Nagpur

Abstract: Sky Saver is a unique personal rescue device which uses an individual harness to help a user safely escape from an emergency situation in a multi-storey building. It is lightweight, self-contained and easy to use. Attach the fire-resistant cable to a secure anchor point, and you can safely lower yourself down the side of the structure. When the situation is serious, and there's little time to react, Sky Saver is the ultimate piece of survival gear for multi-storey occupants. As such, there are certain personal considerations that must be taken into account before a Sky Saver device is issued. Factors can include the user's height, weight, and physical infirmity among other issues.

Key Points: Governor, Rope, Dead Weight, Chain Sprocket and Pedestal Bearing.

I. Introduction

Fires can cause devastating harm to properties and even death to many people. The risk of being injured in a fire or becoming a fire casualty is higher for people with mental, physical and sensory disabilities. The excellent news is that deaths by fire are preventable provided that the person is educated on how to escape from a fire and with devices like a fire alarm and a Sky Saver.

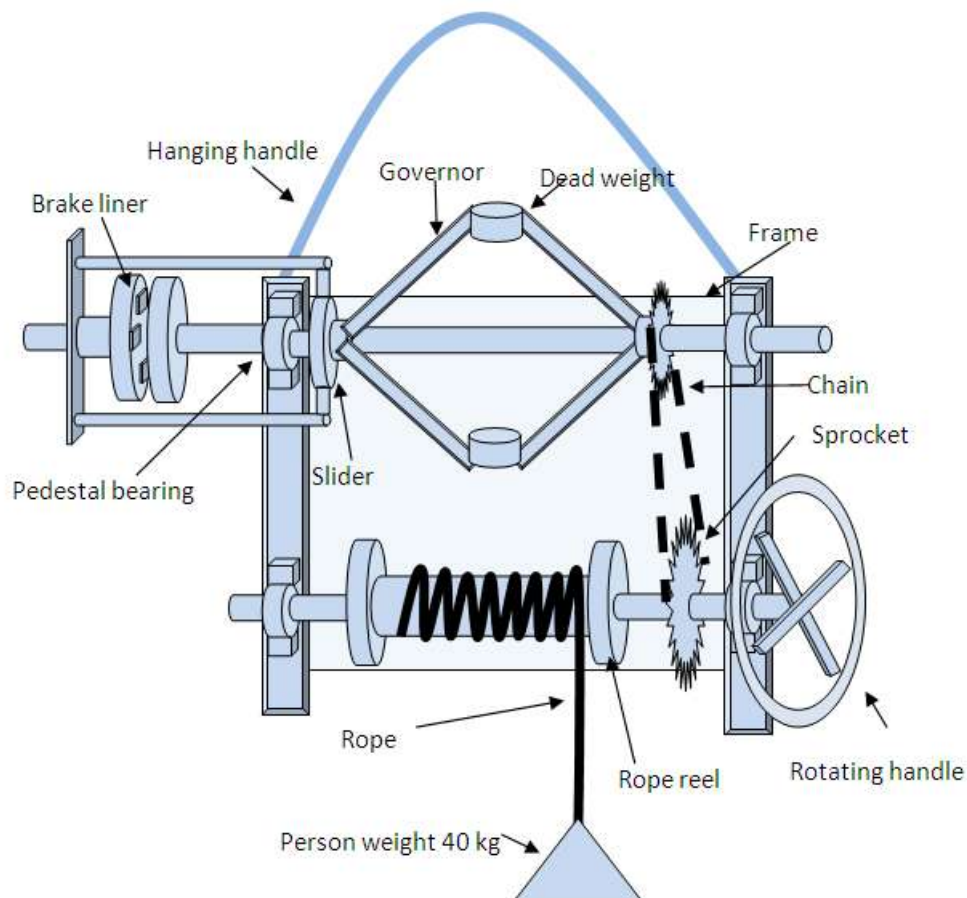

Everyone has a diminished capacity to react in a fire emergency so everyone needs to be careful. Some individuals would not want to change their lifestyle and are independent. This mind-set can cause you to

International Conference on Innovation & Research in Engineering, Science & Technology
(ICIREST-19) 86 | Page

overlook fire safety needs that are necessary. In some circumstances, disabled individuals might require the help of care providers to practice fire safety techniques. It is strongly recommended that you choose a home on the ground floor or first floor of a structure, although you have the right to live where you choose. Additionally, it is advised to have the apartment near a fire exit to make the escape easier.

II. Objectives

- To develop a reusable device that helps the user to reach the ground safely at constant speed.
- To develop a device which requires no advance training for its use.
- To make a product which works mechanically without the need for any outside power
- To develop a low cost device for multiple people.

III. Literature Review

[1] **Sumit Kumarsay** says, In the current investigation, Porter governor is modified such that it increases the controlling force. In modification, the fly-ball is fixed on the lower arm at the small distance below from the point of intersection of arms. The analysis is carried out by mounting the fly ball at the various positions on the lower arm.

[2] **Ravindra Singh Rana** says we have done the Stress analysis on a particular configuration of governor assembly and then various materials are suggested on a theoretical basis. The stress concentration areas, which are most susceptible to failure has been given due attention and studied with depth. According to the analytic study, we found that we have to increase the strength in those areas and to achieve this, the diameter of the shaft should be increased near the base.

IV. Methodology

- The displacement of the various elements of the SPINDLE from the base is also calculated and the graphs are plotted. Effect of the "WEIGHT OF THE ARMS" is the major area of concern for our study and all the calculations are done considering the weight of the arms.
- The objective of our investigation is to identify the stress concentration areas, areas which are most susceptible to failure when governor is rotating about its axis, also the values of these stresses are measured.

V. Working Principle

When weight is pulled down, the rope tends to move the reel. Reel is connected to governor shaft by the chain sprocket. As the speed increases the dead weight on the porter governor tends to move outwards which applies the frictional brake and reduces the speed. When the load is removed, the dead weight comes inside and releases the brake.

Using the above principle, we are using the steering column as lever to get the mechanical advantage by using the pivot and use the smaller distance from the fulcrum to connect the crank link of the wheel to propel the wheel to effect the drive.

VI. Conclusion

The developed prototype exhibits the expected results. Further modifications and working limitations will put this work in the main league of use. This concept saves time & energy which leads to efficient working. This further line should be modeled using equations and an experimental agreement. The product will act as a pioneer in firefighting systems.

VII. Application

1. It can be used in multi storey buildings to save life of persons when required.
2. It can be used in construction sites for material handling purpose.

References

- [1]. R. S. Khurmi, and J. K. Gupta. Theory of machines. S. Chand, 2001
- [2]. B. D. Shiwalkar "Design Data For Machine Element"
- [3]. DR. P Kannaiah 'Machine Design' SciTech publication (I) pvt ltd-2003
- [4]. R.S KHURMI "A text book of machine design" edition 2004
- [5]. N.D BHATT AND V.M PANCHAL "Machine Drawing" Charotar publishing house 24th edition.
- [6]. V.B BHANDARI "Design of machine element" McGraw-Hill publication co. ltd 16th edition.
- [7]. PANDYA AND SHAH "Machine design" Charotar publishing house 13th edition.